

CAMBO

WHERE TRADITION MEETS VISION



ACTUS

View Camera System

Perspective Control - Selective Sharpness - Macro Extension

Cambo – founded in 1946 - is best known for its long history as manufacturer of professional view cameras. Since the introduction of digital SLR cameras Cambo have designed and developed innovative camera platforms. These camera systems are in daily use, in many photo studios around the world.

Presently, with the continuously expanding availability of mirrorless technology, Cambo have designed a new view camera system, adapting the mirrorless bodies as a 'Digital Back'. A digital camera without a mirror box also opens up more possibilities for better quality optics. From the classic 'legacy' large format lenses, enlarger lenses, camera system lenses to the high quality digital lens range from Schneider and Rodenstock - the possibilities are endless.

Since introducing the Actus-B for the mirrorless and DSLR camera bodies, Cambo have expanded the system by designing the Actus-G and Actus-DB, which can host medium format cameras and digital backs on the rear standard. Built from the same components with the same passion, but with new potential in mind.



ACTUS-G with Fujifilm GFX body and Cambo Actar lens

The Actus offers you image control settings, that can only be achieved using a view camera, nevertheless combined in a unique compact and portable camera. Thanks to the tilt and swing possibilities on the front standard and a rear standard offering rise and fall and horizontal shift, photographers will have full control on depth of field, sharpness and perspective.

When using a digital back, you maintain the compatibility with the existing interfaces from Cambo's Sliding Back and WideRS series cameras.

When using a system camera body, the camera body of your choice is attached to the Actus by clicking it on to a rotating bayonet. This allows you to easily transfer from landscape to portrait using one movement without removing anything.

Bayonets are available for the mirrorless Canon, Fujifilm, Hasselblad, Nikon and Sony cameras, the Pentax-K, various Micro 4/3, Leica M and SL cameras and also for Nikon D/F* and Canon Eos*.

* When adapting a DSLR the practical use of wide angle lenses will only be limited possible, due to the mirror box of these cameras bodies and the recessed sensor.



ACTUS-B with mirrorless camera body and Hasselblad Zeiss Planar lens



Let's take a look at the rear standard. It offers 40mm side shift using a quick slide and has a locking knob. The 12mm rise and 15mm fall is driven with a lockable fine gear. The optimum control of perspective enhances your creativity and quality possibilities for landscape, architecture and product photography.

The connection between focal plane and front standard is made with a leather bellows, which is attached using magnets on both standards. It simply clicks on both sides. Apart from the normal bellows you can choose for a shorter wide angle bellows or longer bellows in combination with longer monorails.

The lens plates are fast and easy to exchange thanks to one quick lock. Next to Cambo's ACTAR lenses, there are lens plates for #0, #1 and #3 lenses, and M39 (enlarging) lenses with Leica thread.

You can also choose an adapter plate for lenses with Hasselblad V-bayonet and Mamiya RZ/RB-bayonet, as well as Mamiya 645Pro and Pentax645. More MF may follow.

For cameras using a smaller sensor (like Fuji-X, Micro 4/3) there is a possibility to use 35mm lenses. Cambo offers adapter lens plates with Nikon-F and Leica-R bayonet. For Canon EOS lenses an adapter with electronic aperture control has been added. Most are also usable with certain mirrorless cameras using full-frame sensors, be it limited, based on their specific image circle.

The monorails of the Cambo Actus have both (3/8" and 1/4") mounting threads and are also compatible with the Arca quick release system, such as Cambo's PCH geared head and CBH-6 ball head.

The front standard's tilt can be adjusted by 19°, the swing can do much more, even up to 360°. Needless to say, both by means of high precision fine gearing. These adjustments make it possible to change your selective sharpness plane, either to increase or to specify exactly your selective sharpness plane using Scheimpflug settings.

Rotating the front swing by 180° allows you to mount the lens plate all the way on the front, gaining an extra 48mm of extension for longer lenses or for shooting closer up.



Because all movements are performed with the rear standard, the Actus is ideally designed for stitching. The lens always stays in place, only the rear standard moves, the relative perspective isn't changing!



ACTUS-G

The Cambo ACTUS-G is derived from the ACTUS-B camera system. The Cambo Actus-G is a true cross-platform camera base within the Actus family.

This ACTUS-G version features a quick lock for an interchangeable bayonet. It can be used with many different camera options, including medium format Fujifilm's GFX-50s, Hasselblad's X1D and all bayonets from the Actus-B by using the specific AC-78E holder.

Removing both lens plate and bayonet mount leaves you with a minimal sized package.

Next to that the Actus-G also offers the possibility of mounting an interchangeable frame for digital backs. This flexibility enables quick changing of platforms between camera bodies and digital backs. Choose between the fixed ACDB-989 frame and the sophisticated AC-987 frame with additional $+6^\circ/-6^\circ$ tilt.

The Actus-G features a precision geared side shift and built-in spirit levels for precise levelling.



ACTUS-G with ACDB-987



ACTUS-G with ACDB-989



ACTUS-G with Fujifilm GFX body



ACTUS-G with PhaseOne back

Applications

The use of a view camera means an enhancement of your photographic image creating possibilities.

In the studio, especially with macro, food and product photography, you gain the optimum control within your sharpness plane and depth of field.

This particularly facilitates the use of selective sharpness. During photography of small objects it allows you to relocate the sharpness precisely to the plane where the sharpness is most wanted to show.

The Actus also offers perspective control movements to dedicated architectural, landscape and product photographers who prefer the optical path to achieve this. This small and lightweight camera is extremely portable and is instantly ready to use!





ACTUS-DB-2

The ACTUS-DB-2 is specifically designed for the use of digital backs. The system is using the same SLW interface plates from the well-known Cambo Wide RS series and Cambo's Ultima interfacing systems.

These interface plates can quickly and safely be inserted in either portrait or landscape mode. Digital backs from the manufacturers PhaseOne, Mamiya Leaf, Hasselblad and Sinar are supported, ranging from the entry models up to and including the latest versions. Focussing can be done in several ways, either using the built-in live focussing option of the back, connecting to the software from the manufacturer or via the optional available ground glass frame WDS-619.

ACTUS-DB features a unique weight compensation for the digital back



Bellows click on and off easily with magnets that assure a quick and secure way of attachment. The default included ACDB-250 bellows has an extension that supports up to and including 120mm focal length. Longer extensions for real close-up may require an optional available longer bellows, see the scheme at the rear side.

Lens plates being used in combination with the Actus-DB-2 have a second fitting position that allows for 9mm extra height adjustment. This way a vertical shift of 24mm will be achievable. The optional addition of the new Base Tilt Kit opens up even more indirect shift adjustments.

To synchronise with a digital back lenses with a built-in shutter are needed. The latest generation of digital backs have also sensor-based E-shutters, which enable the use of shutterless lenses, like on the Actus-B and G versions.



The Actus-DB-2 features a convenient infinity stop that limits the quick sliding movement. This serves two functions. Firstly you can set the infinity distance of your lens as a reference point and secondly it protects the rear element from touching the sensor of the digital back.

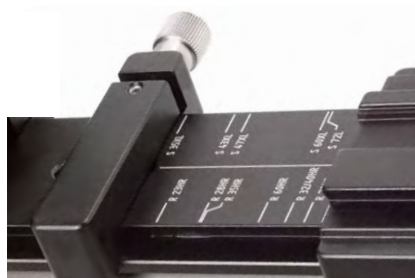

ACTUS Base Tilt kits

You now have the option to expand your ACTUS with an optional Base Tilt function.

Base Tilt is an important feature when you have the monorail inclined and need to place the standards perpendicular again, for yaw-free movements. The use of Base Tilt on both standards also allows you to introduce an additional indirect vertical shift, very useful when lenses are used with a relatively large image circle.



The rear base tilt unit mounts between the rear standard focussing unit and the monorail. An additionally included feature is that this extra layer allows for 42mm more focus draw, compared to the original configuration. The front base tilt unit mounts with 4 screws between the front standard and the monorail. The tripod base tilt unit mounts to the bottom of the monorail and can slide along the full monorail length.

Incremental settings upto 15 degrees are set and locked with a positive lock.

AC-375 gives additional freedom of movements in applying technical camera settings. Next to that, you can set indirect vertical movements by applying base tilt to both standard, increasing more vertical shift when your optics allow for that. By simultaneously applying tilt to the tripod mount, you can keep your standards parallel and perpendicular with an inclined monorail. Ideal for yaw-free swing applications.



ACTAR-15

Actus Camera Lens Perspective Control - Selective Sharpness

Actar-15 is the latest addition to the expanding range of Cambo Actar lenses.

Designed for architectural, interior and landscape photography, it offers an optical system which has almost no geometrical distortion, while still featuring a generous image circle of over 65 mm.

Cambo's ACTAR-15 is an ultra wide-angle lens, dedicated to the Cambo Actus series. Its design allows it to focus at infinity with mirrorless camera bodies.

The generous image circle accommodates for 15mm shifts using 24x36 sensors, while 33x44 MF sensors still allow for up to 6 mm shift.

The optical design is built out of 17 elements, special coated for high contrast.



Technical specifications:

-focal length:	15mm
-aperture range:	f 4.5 - 22
-filter thread:	no filter thread
-image circle:	65mm
-weight:	760 gram
-lens design:	17 element/11 groups
-build for:	Cambo Actus with mirrorless camera bodies
-size L x W x H:	95 x 98 x 130 (includes lens cover)

ACTAR-19

Actus Camera Lens Perspective Control - Selective Sharpness

Cambo's ACTAR-19 is a 19mm wide-angle lens, dedicated to the Cambo Actus series.

The distinctive attribute of this lens is its powerful image circle of over 71mm, while showing virtually no geometrical distortion. The image circle makes this lens usable with all sensor formats from APS upto 150mp Digital Backs.

When the Actar-19 is mounted in combination with a GFX Fujifilm camera series it allows for at least 9mm of shift. Even in relation to a 54x41mm sensor -using the sensor based electronic shutter- a bit of shift is possible before vignetting.

This lens include glass elements that have Nano Crystal Coat which optimises image quality under various conditions.

Technical specifications:

-focal length:	19mm
-aperture range:	f 3.5 - 32
-filter thread:	no filter thread
-image circle:	71mm
-weight:	880 gram
-lens design:	17 element/13 groups
-build for:	Cambo Actus with various camera bodies and DB
-size L x W x H:	121 x 102 x 132 (includes lens cover)



ACTAR-24

Actus Camera Lens Perspective Control - Selective Sharpness

Cambo's ACTAR-24 is a 24mm wide-angle lens, dedicated to the Cambo Actus series.

Thanks to its design it will focus at infinity with mirrorless as well as DSLR camera bodies.

On full frame 24x36 sensors the optics allow for 10mm shifts. Using smaller sensors you may gain more shift, as the Actus offers more adjustments within the lens' 60mm image circle.

While offering a normal wide-angle in one shot, this lens can also be used for more demanding viewing angles using stitching multiple images within its image circle.

The optical design is built out of 16 elements, multicoated for high contrast.

Technical specifications:

- focal length: 24mm
- aperture range: f 3.5 - 22
- filter thread: m82
- image circle: 60mm
- weight: 660 gram
- lens design: 16 element/11 groups
- build for: Cambo Actus (no shutter)
- size L x W x H: 95 x 98 x 130



© Hans Morren
Cambo Actus - Sony A7
Actar-24 lens



ACTAR-35

Actus Camera Lens Perspective Control - Selective Sharpness

Cambo's Actar-35 is a rebuild lens dedicated to the Actus in combination with a dslr or mirrorless camera. This lens is permanently attached to an Actus lens panel and has a focal length of 35mm. This makes it an ideal companion for landscape and architectural photographers.

This ACTAR-35 [retrofit] is based on the Contax Distagon 35 for the 645 system. The electronic aperture is replaced with a manual version, while being rehoused at the Cambo factory.

As the image circle is designed on the 4,5x6 format, there is an optically allowed horizontal shift possible of 10mm each side when using a full frame (24x36) sensor, when using a 33x44 sensor of the MF camera bodies, the shift possibilities limit to 5mm.

Technical specifications:

- focal length: 35mm
- aperture range: f 3.5 - 32
- filter thread: m95
- image circle: 70mm
- weight: 815 gram
- lens design: 16 element/11 groups
- build for: Cambo Actus (no shutter)
- size L x W x H: 116 x 100 x 133



ACTAR-60

Actus Camera Lens Perspective Control - Selective Sharpness



Cambo's ACTAR-60 is a 60mm standard lens, dedicated to the Cambo Actus series. It will focus at infinity in combination with mirrorless camera bodies, not with DSLR bodies, due to its compact design.

The ACTAR-60 is a lens with no geometrical distortion. As the image circle is 75mm, there is an optically allowed horizontal shift possible of 15mm each side when using a full frame (24x36) sensor in landscape mode, and 17mm in portrait mode. When using a smaller APS-C sensor the shift possibilities grow to 20mm. Of course vertical shifts have the same possible numbers in reverse order.

The optical design of this lens is a 6 element, of which all lenses are multicoated to achieve the best contrast.

Technical specifications:

- focal length: 60mm
- aperture range: f 4.0 - 22
- filter thread: m40,5
- lens design: 6 elements/4 groups
- image circle: 75mm
- build for: Cambo Actus (only for mirrorless bodies)
- size L x W x H: 41 x 98 x 130
- weight: 300 gram



ACTAR-80 & 90

Actus Camera Lenses Perspective Control - Selective Sharpness



Cambo's ACTAR-80 and ACTAR-90 are 80mm and 90mm standard lenses, dedicated to the Cambo Actus series. Both will focus at infinity in combination with mirrorless camera bodies as well as DSLR bodies.

Both ACTAR-80/90 lenses are ideal for product photography, including fashion, food and jewellery. An extensive image circle of 85 to 90mm, allows for horizontal shifts over more than 20mm each side when using a full frame (24x36) sensor in either landscape or portrait mode.

The optical design of this lens is a 7 element, of which all lenses are multicoated to achieve the best contrast.

Technical specifications:

- | | | |
|------------------|--------------------------|---------------|
| -focal length: | 80mm | 90mm |
| -aperture range: | f 4.0 - 22 | f 4.0 - 22 |
| -filter thread: | m40,5 | m40,5 |
| -lens design: | 7 elements/5 gr. | 7 el./5 gr. |
| -image circle: | 85mm | 90mm |
| -weight: | 355 gram | 325 gram |
| -size L x W x H: | 47 x 98 x 130 | 44 x 98 x 130 |
| -build for: | Cambo Actus (no shutter) | |



ACTAR-105

Actus Camera Lens Perspective Control - Selective Sharpness

Cambo's ACTAR-105 is a lens dedicated to the Cambo Actus in combination with any DSLR or mirrorless camera, mounted to the Actus. This lens has a focal length of 105 mm. This makes it an ideal companion for dedicated studio and primarily macro photography.



ACTAR-105 is optimised for magnifications between 1:4 and 4:1, featuring a floating element for the best performance at the set magnification.

Technical specifications:

- focal length: 105mm
- aperture range: f 5.6 - 16
- filter thread: m43 x 0,75
- lens design: 8 elem./4 groups
- image circle: 82mm
- size L x W x H: 75 x 98 x 130 mm
- weight: 548 gram
- build for: Cambo Actus (no shutter)

CETONIINAE GOLIATHINI PAIR
Chlorocala africana oertzeni
FROM TANZANIA



Camera: **SONY A7R2+CAMBO ACTUS**
Lens: ACTAR-105 HR-MACRO
Light: 3x flash
Focus Stack: 648 Shots
WeMacro by 200um step



ACTAR-120

Actus Camera Lens Perspective Control - Selective Sharpness

The ACTAR-120 is a macro lens with a focal length of 120mm, dedicated to the Cambo Actus series. It will focus until infinity in combination with all mirrorless and DSLR camera bodies.

ACTAR-120 is a lens which is primarily designed for an optimal performance at close-up range, between 1:1 and 1:10. Nevertheless, this lens can also be used for general purpose photography.

The design of this lens is build of 6 elements, of which all lenses are multicoated to achieve the best contrast.

Technical specifications:

- focal length: 120mm
- aperture range: f 5.6 - 32
- filter thread: m40,5
- lens design: 6 elements/4 groups
- image circle: 100mm
- size L x W x H: 44 x 98 x 130
- weight: 315 gram
- build for: Cambo Actus (no shutter)





Cambo Actus - Sony A7R
- Schneider 120 Macro
Digitar
Images by 51 Degrees
North Studios (UK)

When shooting food and product photography, you will need the optimum control over your sharpness. Setting your sharpness plane where you need it, setting a very shallow depth of field where you want it, control this accurately by using tilt and swing; either one of these or both simultaneously - that is the art of photography.

Scheimpflug settings are used for selective sharpness. The Cambo ACTUS series allows you to optimise these adjustments, no matter what lens is mounted on the front standard. Of course, a larger image circle will allow for additional image shifts, but even with a small image circle you can take advantage of the depth of field corrections.

ACTUS-REPRO

Actus Camera Body Macro Extension - Flat Art Reproduction

Cambo has developed a dedicated ACTUS-REPRO version, optimised for flat reproduction assignments.

Its front standard has no tilts and shifts in order to maintain absolute parallel adjusted setting between lens and sensor.

The Actus Repro can be customised with longer monorails and macro bellows and comes with a dual fine focus drive by default. Your bayonet choice is similar to the normal Actus range. This feature makes the Actus-repro deployable with a broad range of camera bodies.

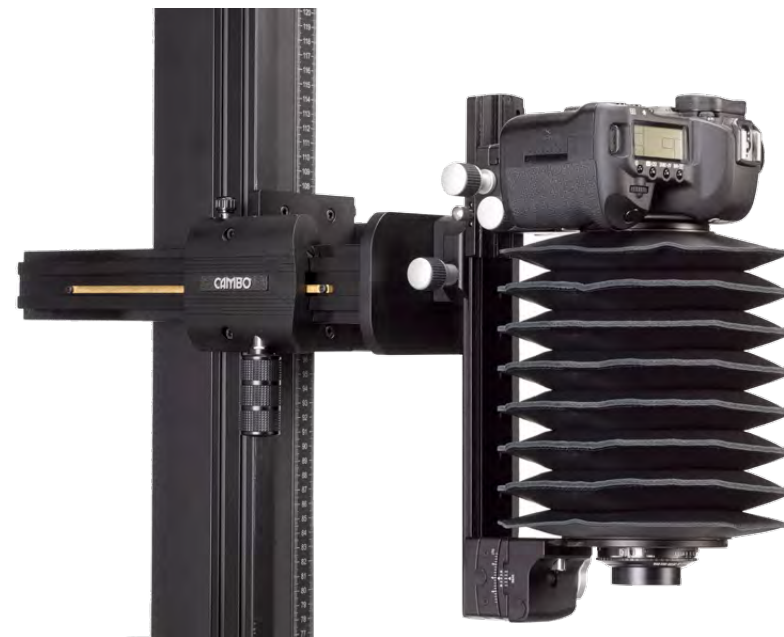

Your lens choice will be based on the desired magnification.

From A4 size down to the smallest subjects the Actar-105 is the prime choice for reproductions between 1:10 and 5:1, with a floating element for optimised results between 1:4 and 4:1.

For larger items or less magnification the Actus-Repro accepts the same Actar lenses and adapting lens panels for third party lenses as offered for the regular Actus B and G versions.

As Repro set-ups are often custom built, Cambo can assist with advise for the best choice of Actus-Repro components.

Accessories for ACTUS-B and ACTUS-G:



ACTAR-15 ACTAR-19 ACTAR-24 ACTAR-35 Retrofit ACTAR-60 ACTAR-80 ACTAR-90 ACTAR-105 Macro ACTAR-120



ACB-0 ACB-1 ACB-39 ACB-HA ACB-RZ ACB-M645 ACB-P645 ACB-LR ACB-NF



ACB-CA AC-324 Lens hood AC-780 Canon EF-mount AC-781 Canon M-mount AC-782 Canon R-mount AC-783 Nikon F-mount AC-785 Leica M-mount AC-786 Sony E-mount AC-787 Pentax K-mount



AC-210 Standard bellows 150mm extension AC-212 Short bellows 40mm extension AC-214 Extended bellows 200mm extension AC-215 Long bellows 300mm extension AC-216 Macro bellows 450mm extension AC-356 Spirit level set for rear standard *Actus-B only AC-788 Micro 4/3 AC-789 Olympus OMD AC-790 Fujifilm X-mount

Accessories for ACTUS-G only:



AC-78E for: AC-780 AC-781 AC-782 AC-783 AC-785 AC-786 AC-787 AC-788 AC-789 AC-790 AC-784 Nikon Z-mount AC-791 Leica SL-mount AC-792 Fujifilm G-mount AC-793 Hasselblad XCD



AC-795 Fujifilm GFX100 mount Kit ACDB-987 DB frame +tilt ACDB-989 DB frame

Accessories for ACTUS-DB and ACTUS-G with DB-mount:



SLW-80 SLW-81 SLW-83 SLW-84 SLW-87 SLW-89



ACB-HVSA ACB-WRS ACB-ALP WDS-619 WRS-1068 WDS-616

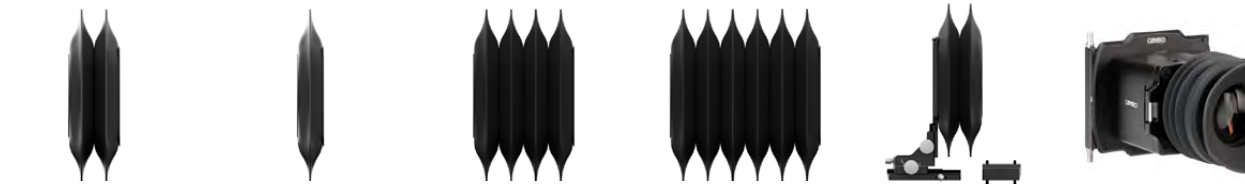

ACDB-250 ACDB-252 ACDB-254 ACDB-256 ACDB-951

Accessories for all ACTUS-systems:



AC-371 Rear Base Tilt Kit AC-373 Dual baseTilt Kit AC-375 Full Base Tilt Kit



PCH - PCF Dedicated Geared Head for ACTUS CBH-6 Dedicated Ball Head for ACTUS



AC-FC500 Focus whip set



AC-315 - AC-330 - AC-345 Monorails for ACTUS lengths 155mm, 300mm, 450mm

Always check www.cambo.com for latest additions and changes

CAMBO Actus System

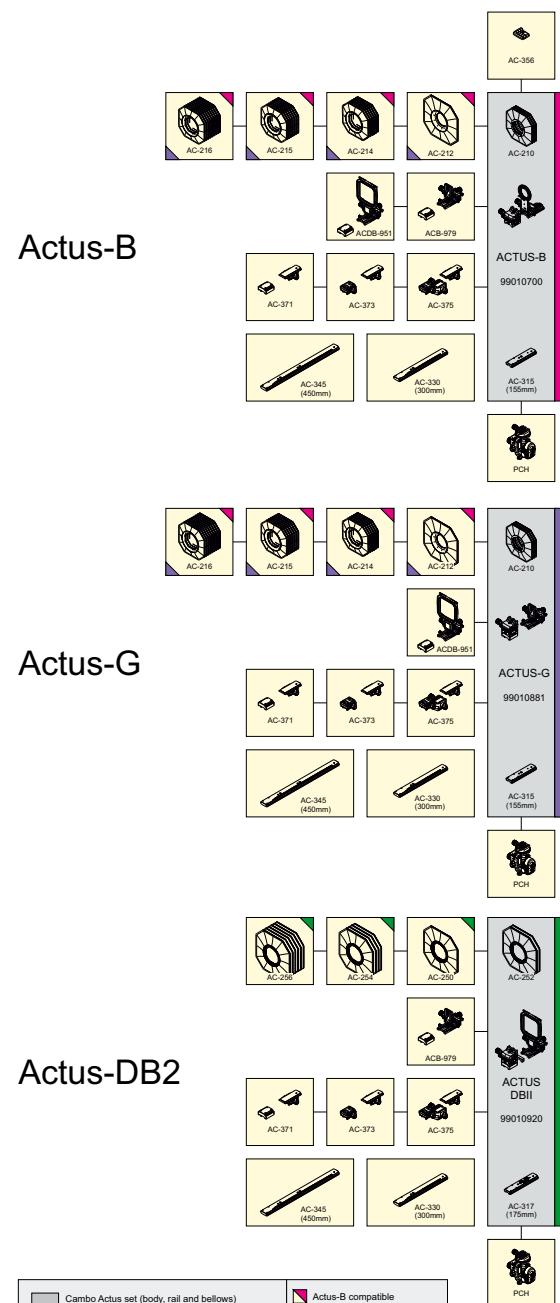

Combo Actus set (body, rail and bellows)
 Third party items (camera body and lens)
 Optional choices (Actus accessories)
 * Short barrel only, depends on focal length
 ** Schneider-Kreuznach lenses = only legacy lenses

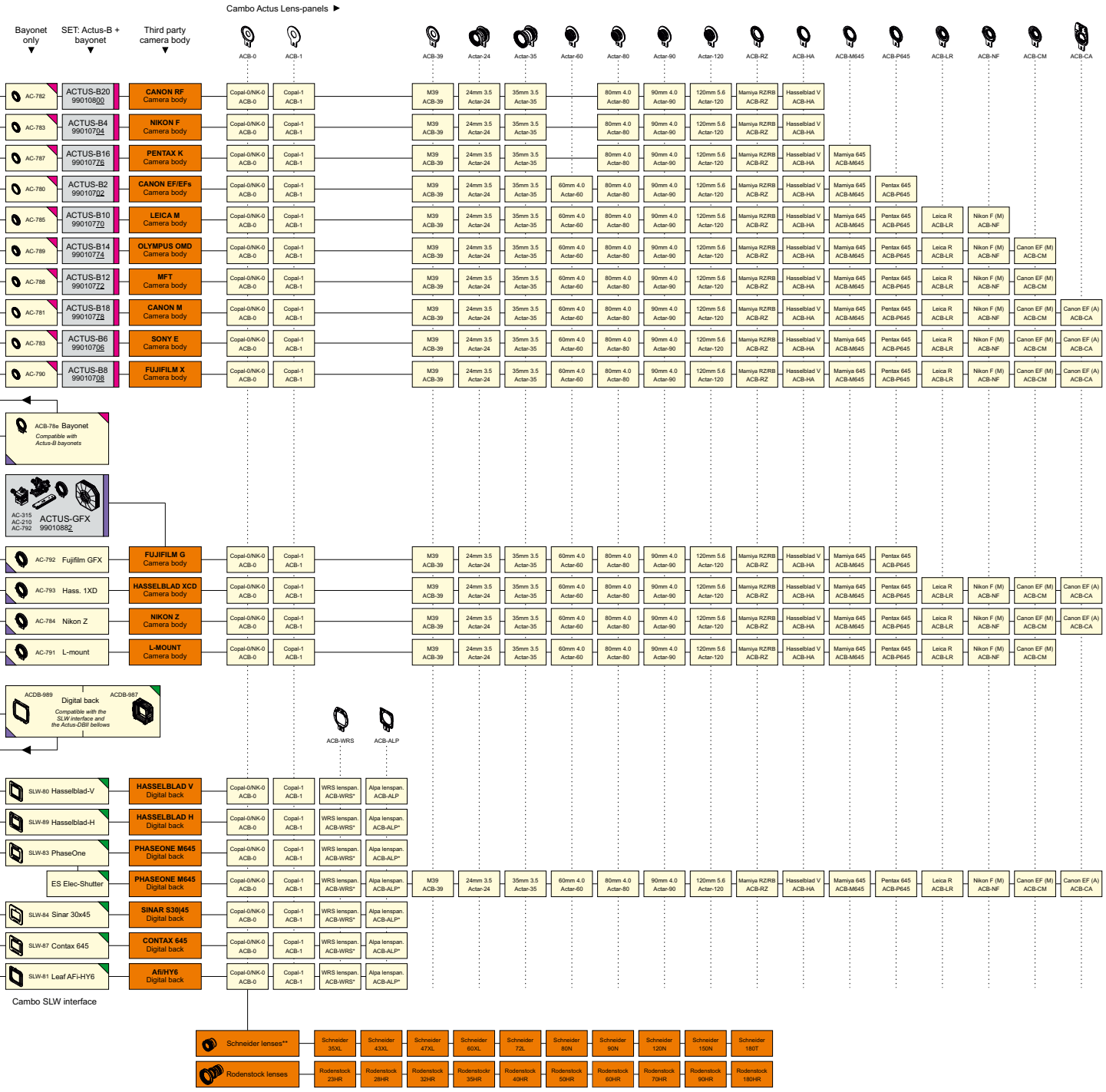

Schneider lenses**	Schneider 30L	Schneider 42L	Schneider 47L	Schneider 50L	Schneider 72L	Schneider 80L	Schneider 90L	Schneider 120L	Schneider 150L	Schneider 180L
Rodenstock lenses	Rodenstock 28HR	Rodenstock 28HR	Rodenstock 32HR	Rodenstock 35HR	Rodenstock 43HR	Rodenstock 50HR	Rodenstock 60HR	Rodenstock 70HR	Rodenstock 90HR	Rodenstock 130HR

Technical Specifications ACTUS-B / G:

Size (L x W x H): 155 x 100 x 170 mm / 155 x 100 x 86 mm
 Weight (incl. bellows): 1100 gram
 Front Swing: 360°
 Front Tilt: 19° (+10/-9)
 Rear Shift vertical: 27mm (12/15)
 Rear Shift horizontal: 40mm (20/20)
 Focus reach: (lensplate to focal plane)
 up to 138mm (Sony E-mount)
 up to 164mm (Canon EOS-mount)
 up to 166mm (Nikon F-mount)

Lens plates options:
 Copal #0, #0 Flat, #1
 Hasselblad C Bayonet
 M39 Leica thread
 Mamiya RZ/RB bayonet
 Mamiya 645 Pro bayonet (mirrorless b. only)
 Pentax 645 bayonet (mirrorless bodies only)
 Leica R Bayonet (for mirrorless bodies only)
 Nikon-F Bayonet (for mirrorless bodies only)
 Canon-EOS bayonet (mirrorless bodies only)

Camera Bayonet options:
 Canon EOS body *except 1D(s) series
 Canon EOS R body
 Canon M body
 Nikon F-mount body *except D5/D6 series
 Nikon Z-mount body *on Actus-G only
 Sony E-mount body
 Leica M-mount body
 Leica SL-mount body *on Actus-G only
 Fujifilm X-mount body
 MFT/Olympus OMD series body
 Pentax K-mount body
 Hasselblad X1D body *on Actus-G only
 Fujifilm GFX-mount *on Actus-G only
 Fujifilm GFX-100mount *on Actus-G only

Technical Specifications ACTUS-DB-2:

Size (L x W x H): 175 x 115 x 190 mm
 Weight (incl. bellows): 1200 gram
 Front Swing: 360°
 Front Tilt: 19° (+10/-9)
 Rear Shift vertical: 27mm (12/15)
 Rear Shift horizontal: 40mm (20/20)
 Focus reach: (lensplate to focal plane)
 up to 165mm (standard rail)
 up to 290mm (opt. longer rail)
 up to 440mm (opt. macro rail)

Lens plates options:
 Copal #0, #0 Flat, #1, #3
 ACB-HVSA (for Hasselblad 500 lenses)
 WRS Adapting plate (for short barrel)
 ALPA Adapting plate (for short barrel)
 Options without shutter (only with digital back having an E-shutter)

Digiback Interface options:
 Hasselblad-V
 Hasselblad-H
 PhaseOne/Leaf Mamiya
 Contax645
 Leaf Afi/Sinar HY6
 Sinar 30/45

Analog options:
 WDS-619 ground glass
 WDS-616 viewing loupe
 WDS-630 shiftable viewing loupe
 WRS-1068 RF back adapter

Actus Packing*:
 Boxed in a foam interior that fits directly into an optional Pelistorm Case iM2075

*Actus-B, G and DB-2

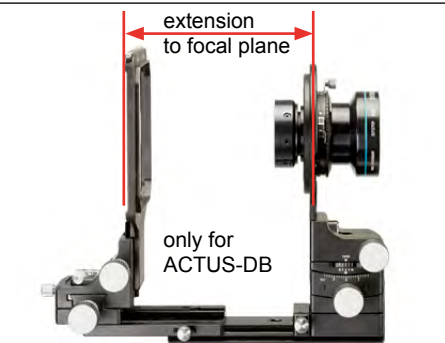

Focal length:	Infinity reach:	Bellows needed:	1:1 possible:	Bellows advised:
Rodenstock:				
23HR	yes	wide	yes	normal
28HR	yes	wide	yes	normal
32HR	yes	normal	yes	normal
35HR	yes	normal	yes	normal
40HR	yes	normal	yes	normal
50HR	yes	normal	yes	normal
60HR	yes	normal	yes	long
70HR	yes	normal	AC-330	long
90HR	yes	normal	AC-330	long
105	yes	normal	AC-330	long
135	AC-330	long	AC-330	long
180	AC-330	long	AC-345	macro
Schneider:				
35XL	yes	wide	yes	normal
43XL	yes	wide	yes	normal
47XL	yes	normal	yes	normal
60XL	yes	normal	yes	long
72L	yes	normal	AC-330	long
80N	yes	normal	AC-330	long
90N	yes	normal	AC-330	long
120L	yes	normal	AC-330	long
150L	AC-330	long	AC-345	macro



CAMBO Fotografische Industrie BV
 Haatlanderdijk 45 - P.O.Box 200
 NL-8260 AE Kampen
 The Netherlands
 Tel : +31(0)38 3314644
 Email: info@cambo.com
 Web : www.cambo.com

